



# CITY

7635





1

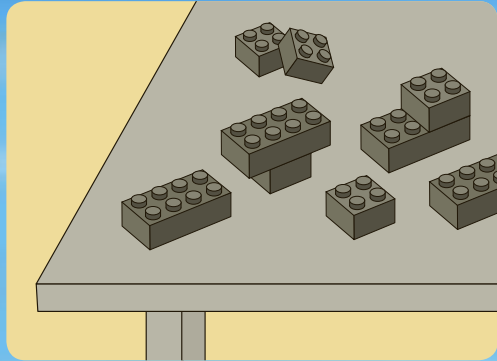
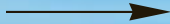

2

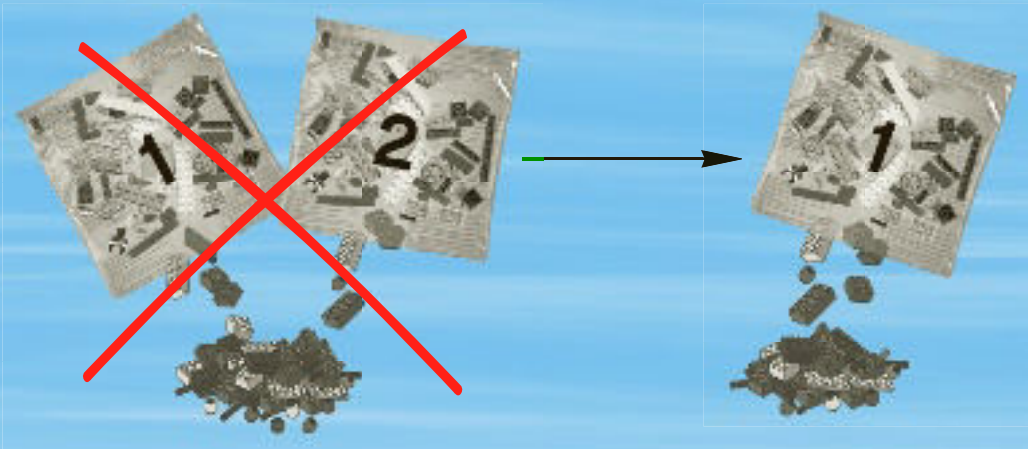

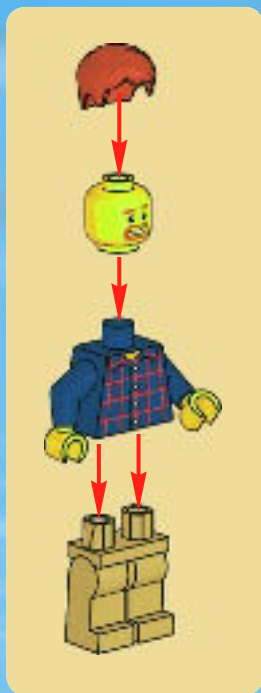

1



2

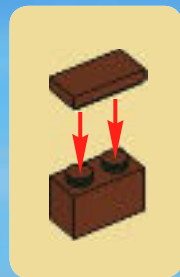

1

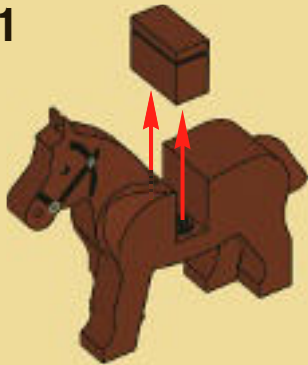

2

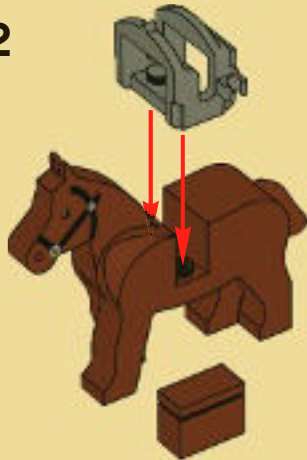



1

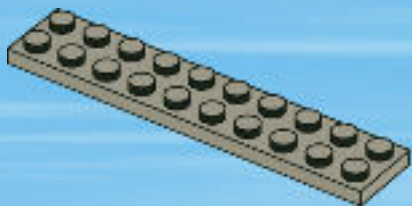

2

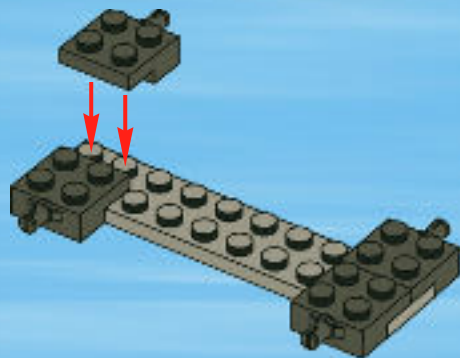

3

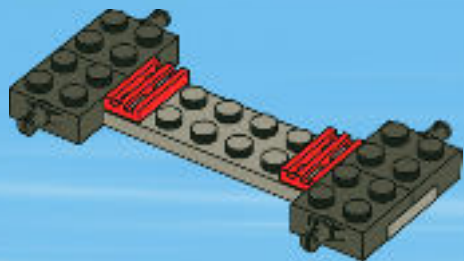

4

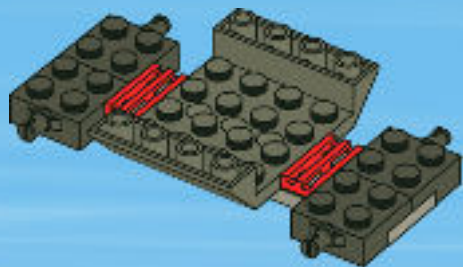



5

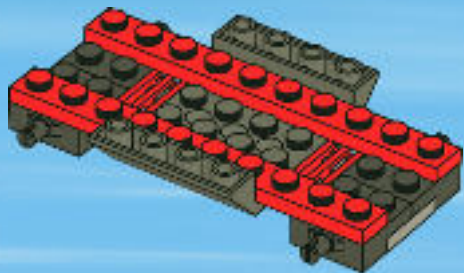

6

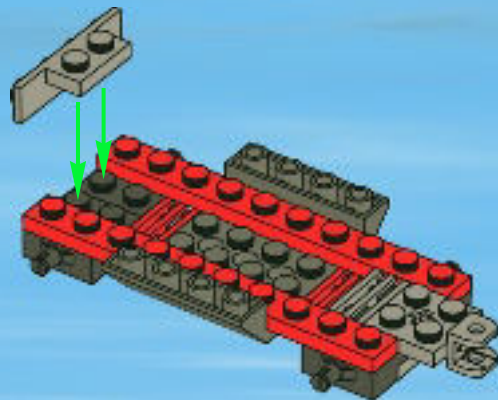

7

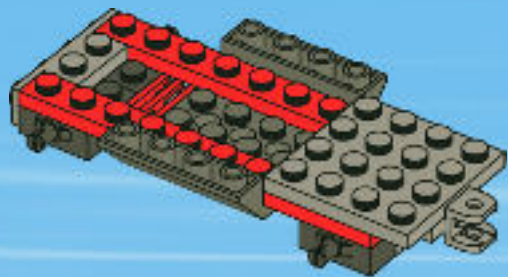

8

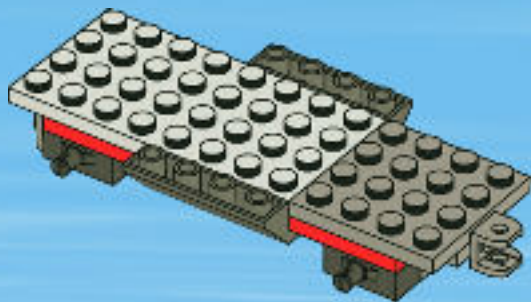

9

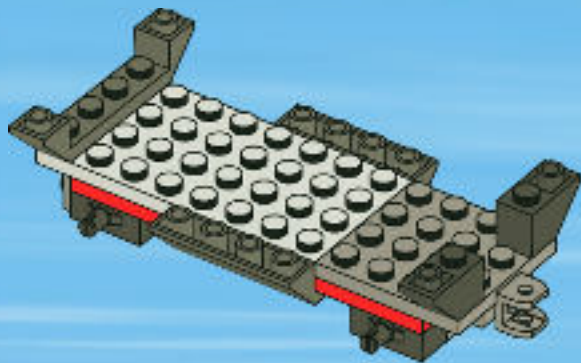

10

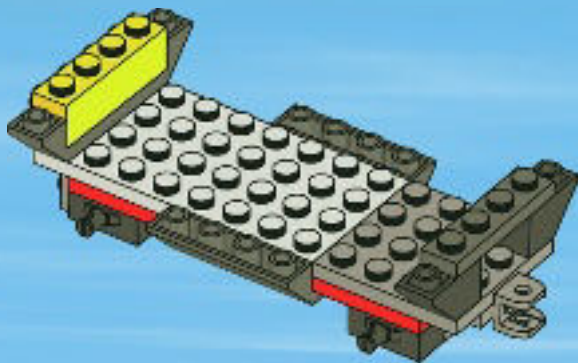

11

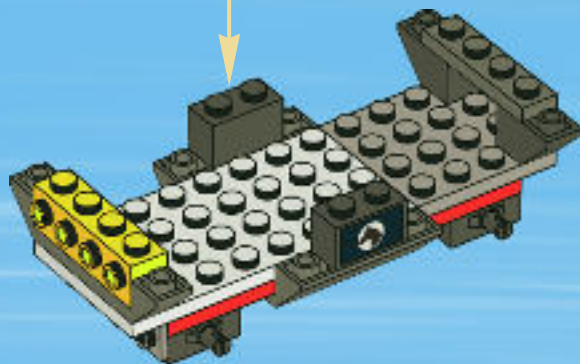
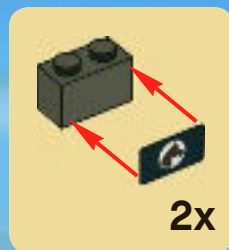

12

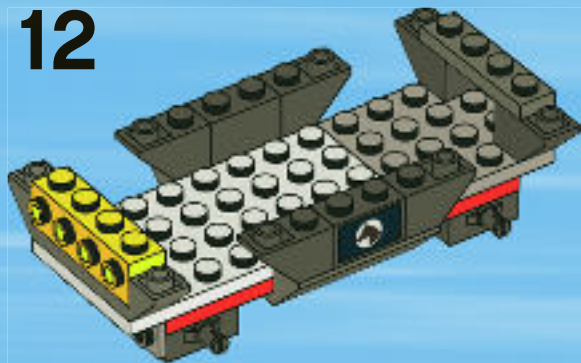

13

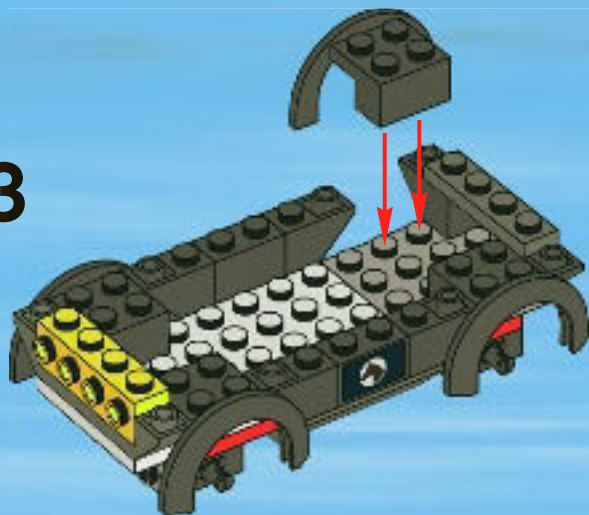

14

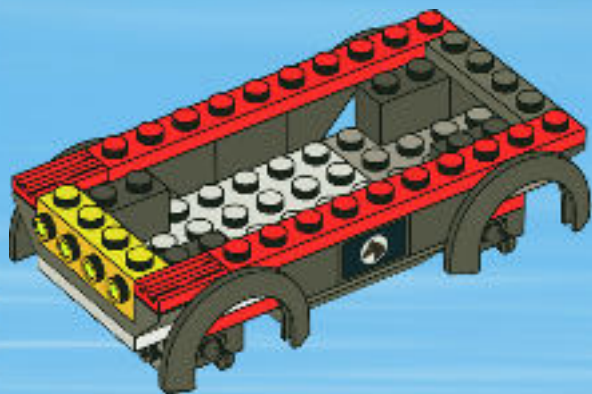

15

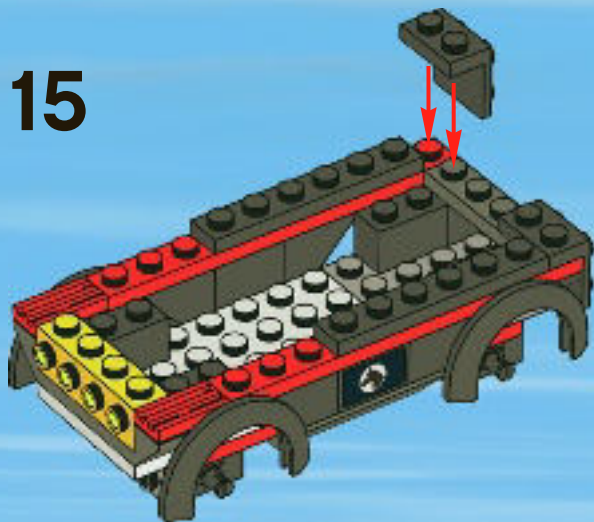

16



17

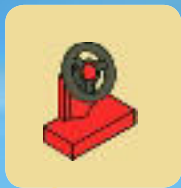

18

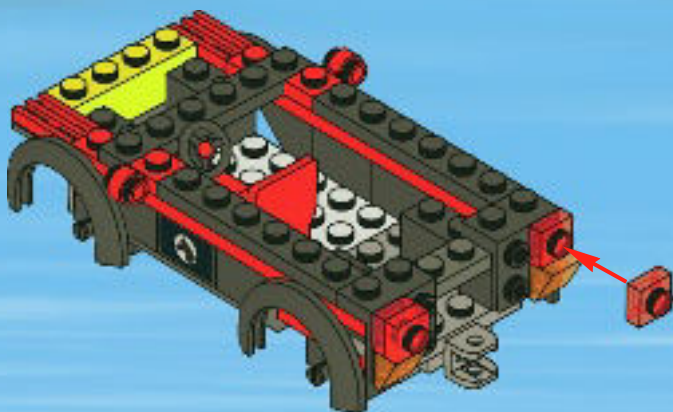



19

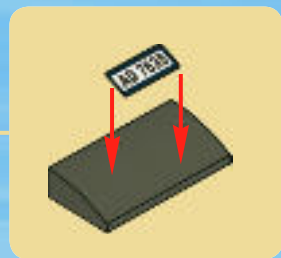
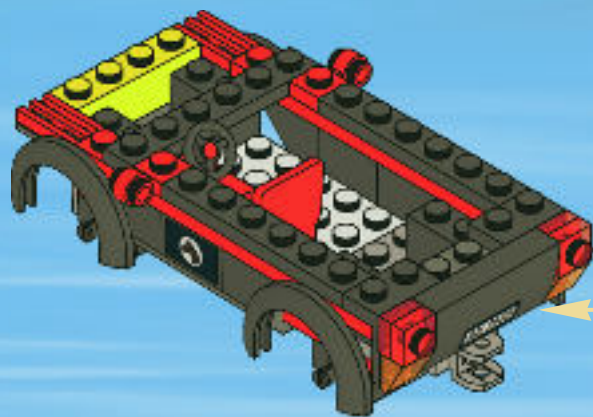

1



2



3



4



20

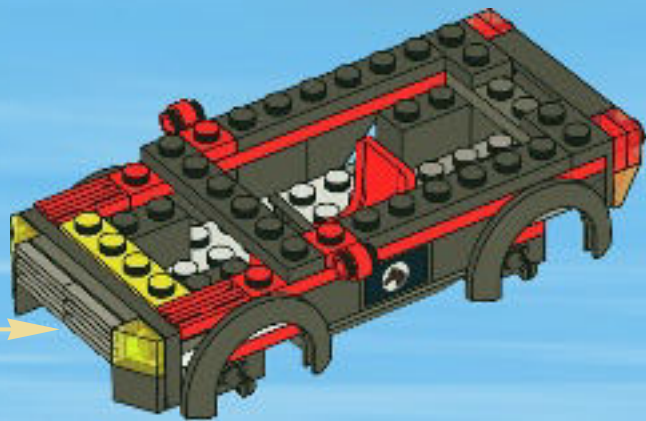

1

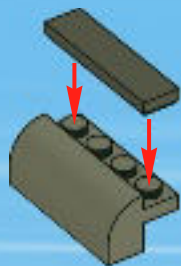

2

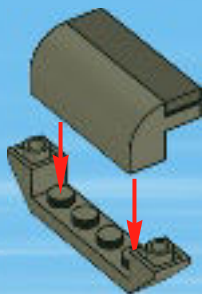

3



21

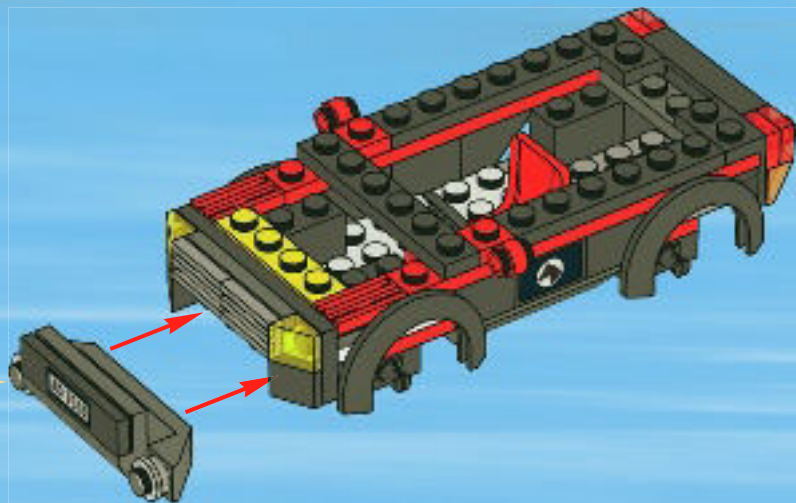

22

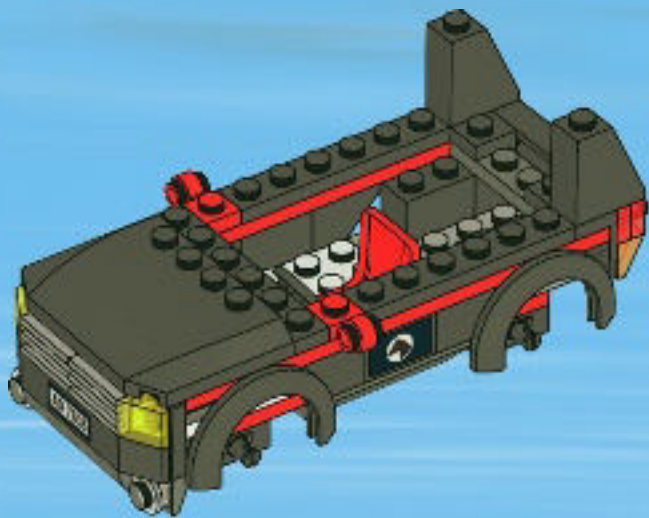

23

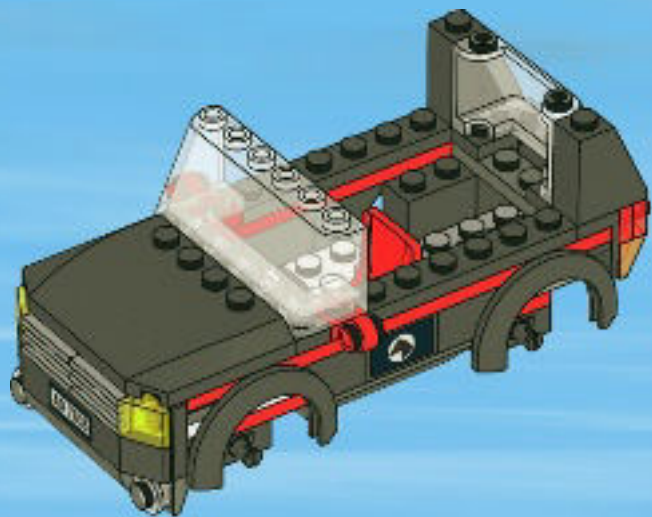

24

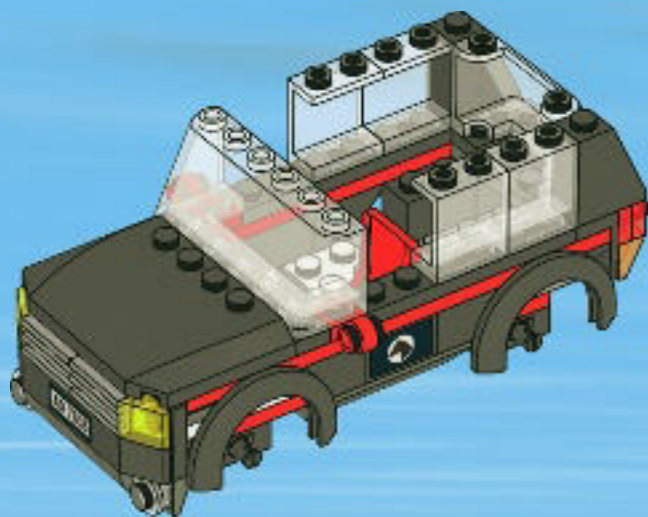



25

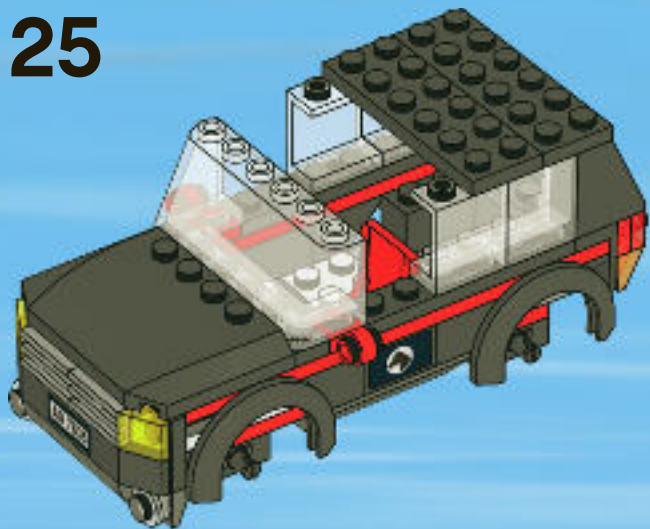

26

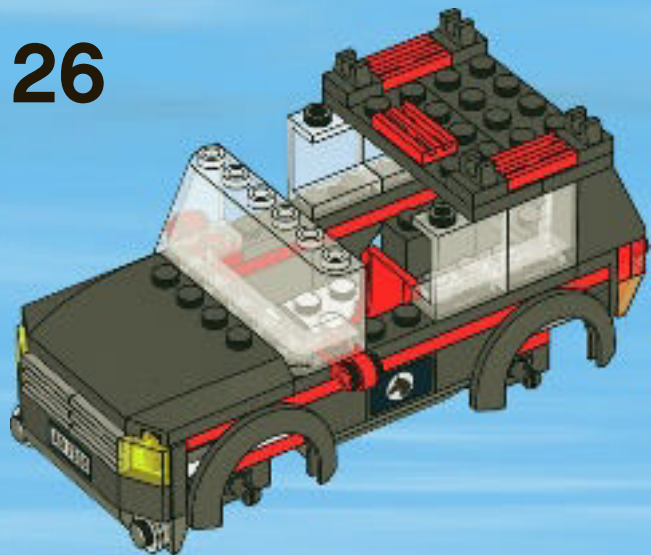

27



28





1

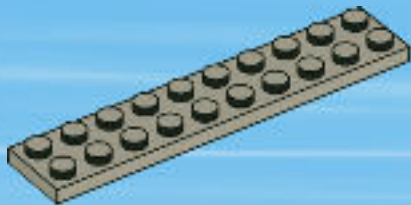

2

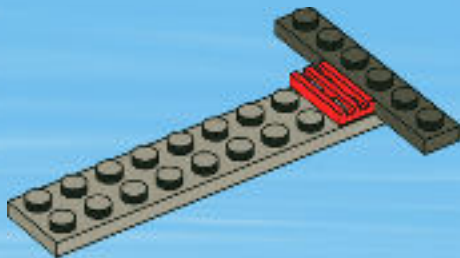

3

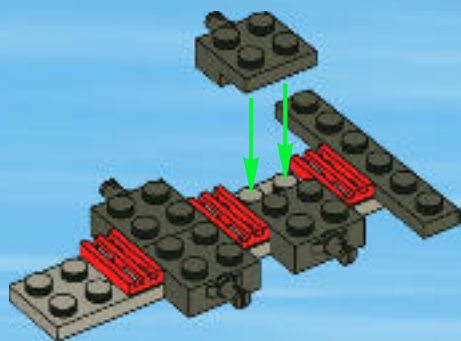

4

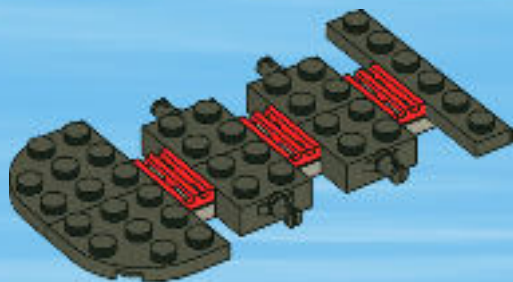

5



6



7

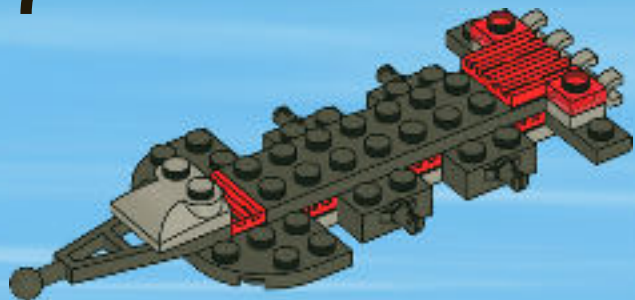

8

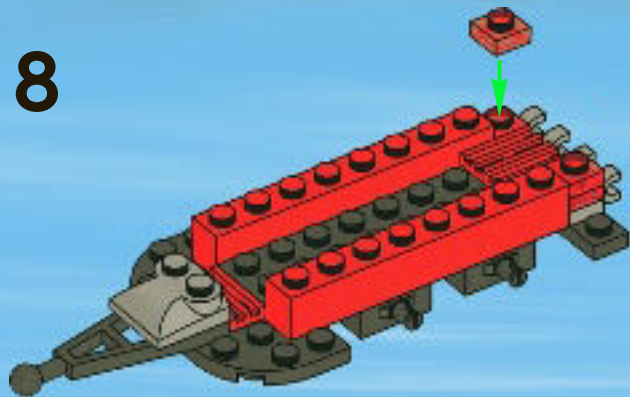

9

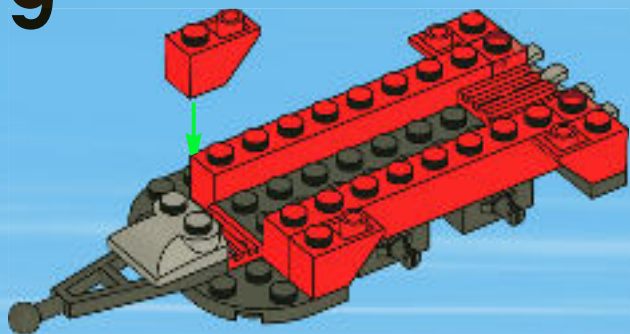

10

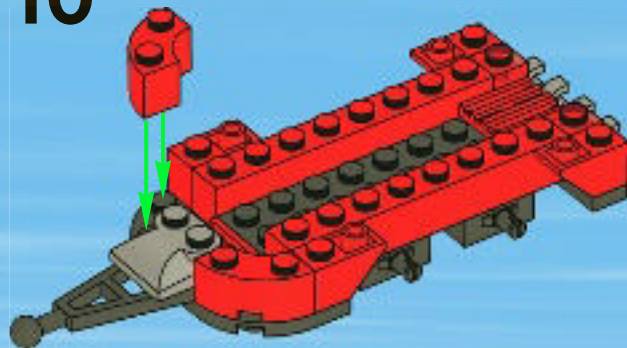



11

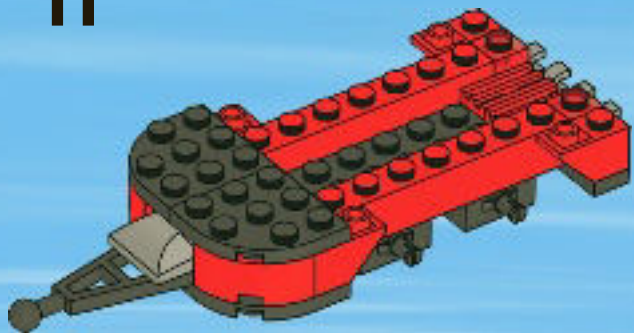

12

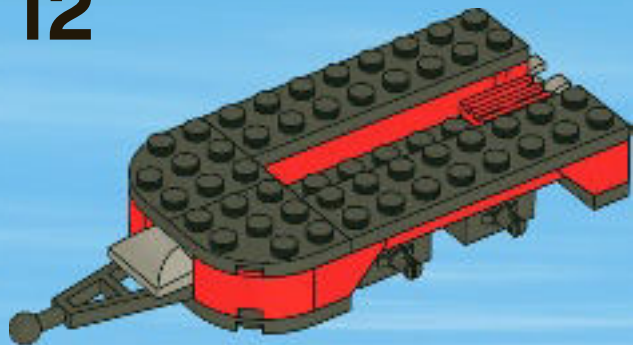

# 13

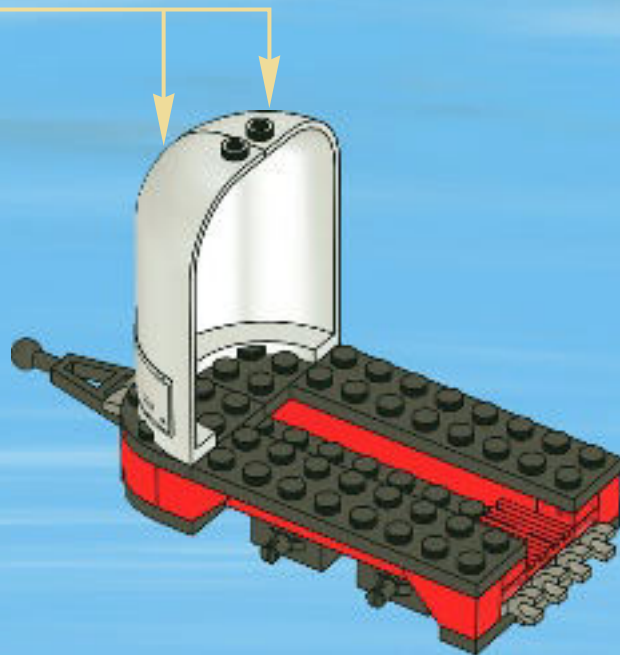
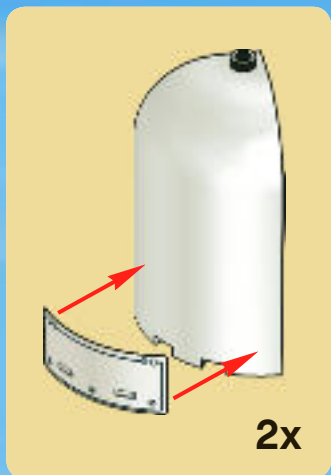

14

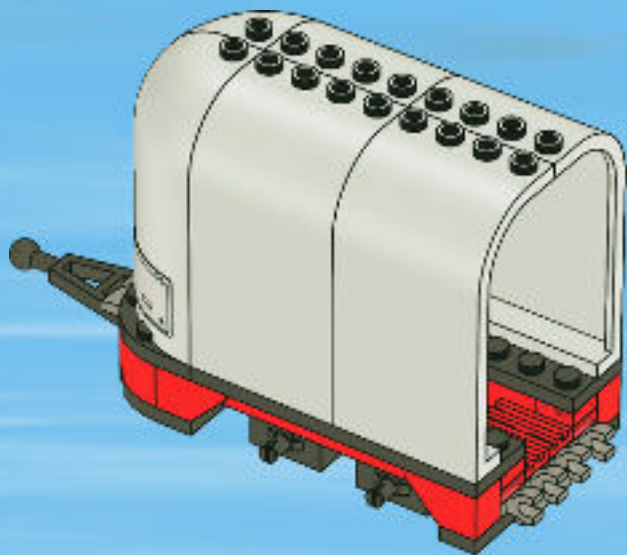

15

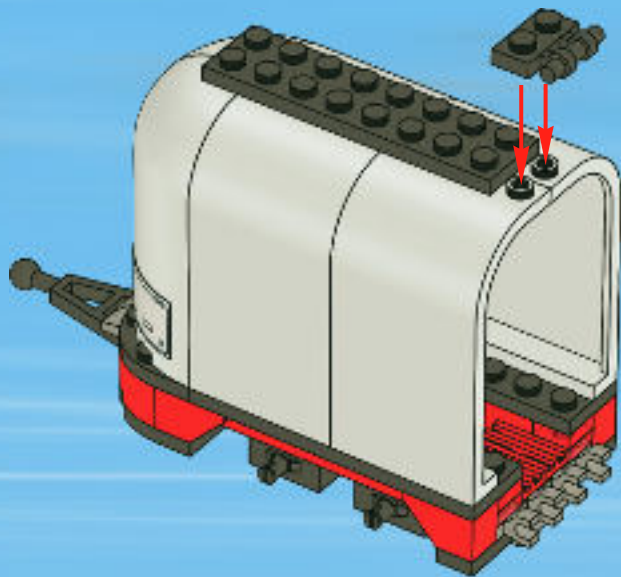

16

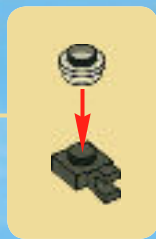
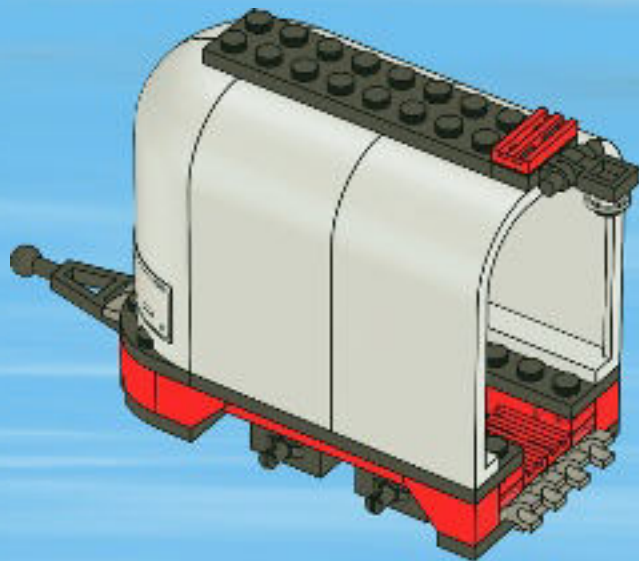

1



2



3



4



5



6

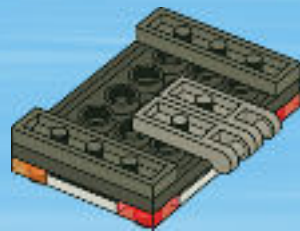

17

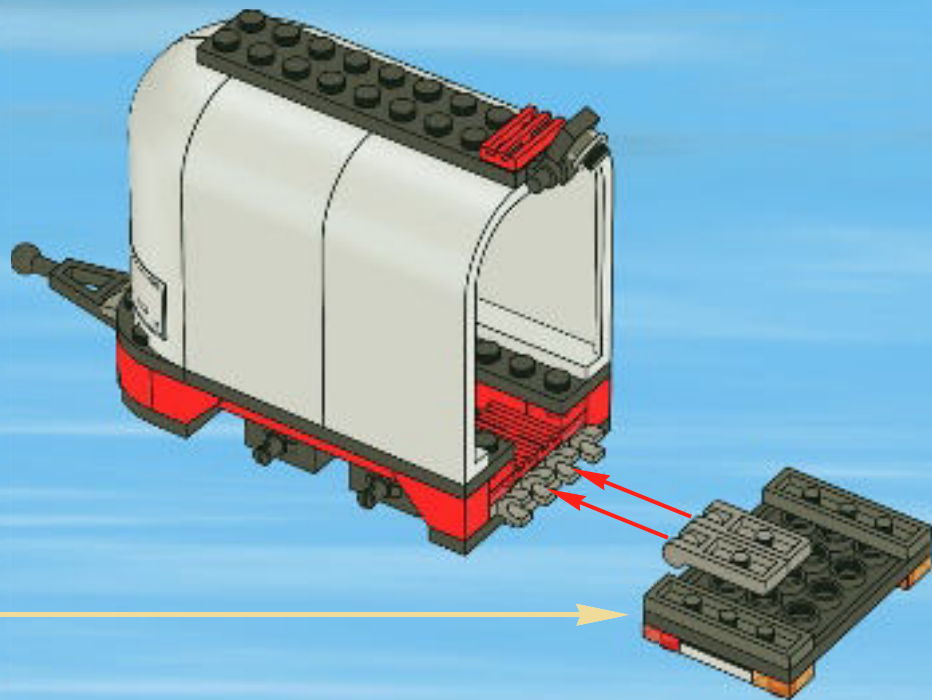

18

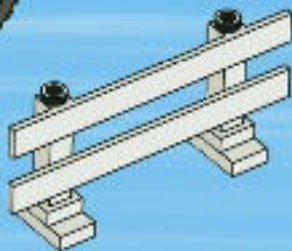
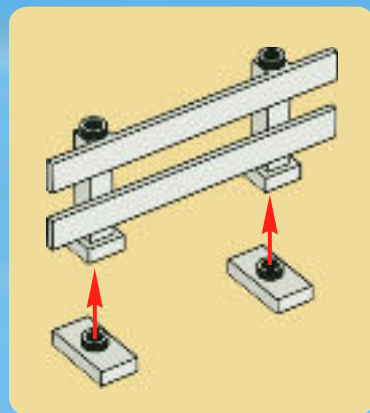







1x  
303501



1x  
4541808



2x  
306901



1x  
243101



1x  
9327



2x  
379401



2x  
4541951



4x  
4497735



2x  
300821



4x  
447721



14x  
241221



4x  
366521



1x  
407921



2x  
4161412



1x  
9552



2x  
4170375



10x  
3000841



2x  
4260942



1x  
4164073



1x  
4186392



1x  
4293369



1x  
4275821



1x  
4275491



2x  
4277932



8x  
448826



2x  
300426



4x  
4260488



1x  
243126



1x  
4542670



4x  
255526



1x  
4517925



1x  
4140588



1x  
4274405



4x  
366626



3x  
379526



4x  
303426



4x  
4227392

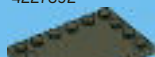

1x  
4100378



2x  
4542671



1x  
4516431



4x  
4504382

6x  
366526



2x  
4515373



8x  
4514560



1x  
4282740



2x  
4211628



2x  
4515173



1x  
4494475



3x  
4211350

1x  
4530469



2x  
4515369



8x  
4211764



2x  
4211462



1x  
4243797

1x  
4210968



1x  
4267282



1x  
4212508



2x  
4294180



4x  
4211001

3x  
3005740



4x  
4113028



1x  
382340



1x  
4502193



2x  
4542673



2x  
4244369

1x  
4211149



1x  
4211151



1x  
4506843

1x  
4107623



1x  
4529755



Customer Service

Kundenservice

Service Consommateurs

Servicio Al Consumidor

[www.lego.com/service](http://www.lego.com/service) or dial

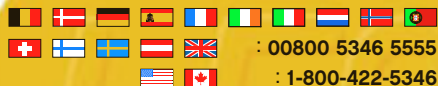

: 00800 5346 5555

: 1-800-422-5346

**LEGO**

**CITY**



7630



7631



7632



7633

**LEGO**

**CITY**



7634



7635



7636



7637



# CITY



46

7279



7285



7286



7287



7288



7498



[www.LEGOclub.com](http://www.LEGOclub.com)



LEGO® Club Email



LEGO® Club Magazine

**LEGO** club™

**FREE! GRATIS! GRATUIT!**

**SIGN UP ONLINE!**

**[www.LEGOclub.com](http://www.LEGOclub.com)**



**00800 5346 5555\***



**1-866-534-6258 • 1-877-518-5346**

US & Canada only

Outside Switzerland

- \* Freephone. Mobile charges may apply.
- \* Numéro sans frais. Des frais peuvent s'appliquer avec les téléphones cellulaires.
- \* Gebührenfrei. Kosten für Anrufe aus Mobilfunknetzen können abweichen.
- \* Gratis telefoonnummer vanaf vaste lijn.
- \* Det er et gratis nummer, når du ringer fra fasttelefon.
- \* Det är gratis, när du ringer från en fast telefon.
- \* Numéro sans frais. Des frais peuvent s'appliquer avec les téléphones portables.



# WIN!

Go to [www.LEGOsurvey.com/product](http://www.LEGOsurvey.com/product) to fill out a survey for a chance to win a cool LEGO® Product.

No purchase necessary.

Open to all residents where not prohibited.



# [www.LEGOsurvey.com/product](http://www.LEGOsurvey.com/product)

## GEWINNE!

Nimm an der Umfrage auf [www.LEGOsurvey.com/product](http://www.LEGOsurvey.com/product) teil und hab die Chance ein cooles LEGO® Produkt zu gewinnen!

Die Teilnahme am Gewinnspiel führt zu keinerlei Kaufverpflichtungen. Teilnahme in allen nicht ausgeschlossenen Ländern möglich.

4639196

## WIN!

Ga naar [www.LEGOsurvey.com/product](http://www.LEGOsurvey.com/product), vul een enquêteformulier in en maak kans op een cool LEGO® product.

Geen aankoopverplichting. Iedereen mag deelnemen, uitgezonderd ingezetenden van landen waar een enquêteverbod geldt.

## GAGNE!

Visite [www.LEGOsurvey.com/product](http://www.LEGOsurvey.com/product) pour répondre à un questionnaire et avoir une chance de gagner un produit LEGO® très cool!

Aucune obligation d'achat. Ouvert à tous les résidents des pays autorisés.

LEGO and the LEGO logo are trademarks of the LEGO Group. ©2011 The LEGO Group.

## 当てよう!

[www.LEGOsurvey.com/product](http://www.LEGOsurvey.com/product) にアクセスして、アンケートにご記入ください。当選者にはレゴ®製品を差し上げます。

お買い上げの必要はありません。禁止されていない限り、すべての皆様にご利用いただけます。